

10/100Mbps **DELTA CLASS** AutoTwister™

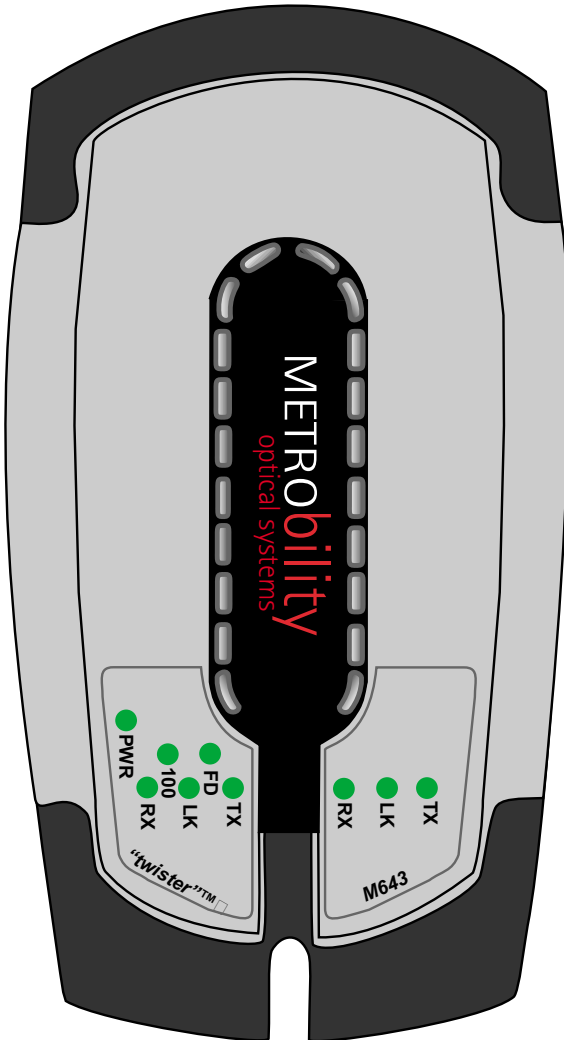

Installation and User's Guide

This manual cover the following Metrobility 10/100Mbps Delta Class AutoTwister models:

M643-13	_____	10/100Mbps TX to 100Mbps FX multimode SC
M643-14	_____	10/100Mbps TX to 100Mbps FX singlemode SC
M643-15	_____	10/100Mbps TX to 100Mbps FX multimode ST
M643-17	_____	10/100Mbps TX to 100Mbps FX singlemode SC (40km)
M643-1G	_____	10/100Mbps TX to 100Mbps FX multimode VF-45
M643-1J	_____	10/100Mbps TX to 100Mbps FX singlemode SC (100km)
M643-1K	_____	10/100Mbps TX to 100Mbps FX multimode LC
M643-1M	_____	10/100Mbps TX to 100Mbps FX singlemode LC
M643-1X	_____	10/100Mbps TX to 100Mbps SC bidirectional wavelength division multiplexed (BWDM) 1550/1310nm
M643-1Y	_____	10/100Mbps TX to 100Mbps SC BWDM 1310/1550nm

This publication is protected by the copyright laws of the United States and other countries, with all rights reserved. No part of this publication may be reproduced, stored in a retrieval system, translated, transcribed, or transmitted, in any form, or by any means manual, electric, electronic, electromagnetic, mechanical, chemical, optical or otherwise, without prior explicit written permission of Metrobility Optical Systems, Inc.

© 2002 Metrobility Optical Systems, Inc.

All rights reserved.

Printed in USA.

Metrobility Optical Systems, the Metrobility Optical Systems logo, and AutoTwister are trademarks of Metrobility Optical Systems, Inc.

The information contained in this document is assumed to be correct and current. The manufacturer is not responsible for errors or omissions and reserves the right to change specifications at any time without notice.

Contents

Overview	4
Key Features	4
Installation Guide	5
Unpack the AutoTwister and Accessories	5
Attach the Rubber Feet	5
Choose an Appropriate Location	5
Set the Switches	6
Connect to the Network	9
Apply Power	12
User's Guide	13
LED Indicators	13
Factory Settings	14
Link Loss Return (LLR)	15
Link Loss Carry Forward (LLCF)	16
Auto-Recovery	17
Auto-Recovery Application Example	18
Topology Solution	19
Technical Specifications	20
Product Safety, EMC, and Compliance Statements	22
Warranty and Servicing	23

Overview

Sleek, compact, and rich in features, Metrobility's 10/100Mbps Delta Class AutoTwister looks as great as it operates. Designed for desktop use in any modern office, the durable AutoTwister meets strict US and international EMC regulations. This versatile device allows you to extend copper-based network distances up to 100km, connect 10Mbps devices to 100Mbps devices, and convert from copper to fiber as well as from half to full duplex. New features include a wall mounting option, highly visible LEDs on the top, and built-in cable management and protection.

To eliminate trips by network technicians to physically reset the unit following a link failure, the AutoTwister includes auto-recovery to automatically restore link on the fiber line after a link loss event. Auto-recovery works in conjunction with Link Loss Return and Link Loss Carry Forward, two additional troubleshooting aids provided to identify the loss of a remote network connection.

On select models, bidirectional wavelength division multiplexing (BWDM) offers an interface that carries two separate channels in different directions through a single strand of fiber. BWDM eliminates the need to install a second fiber and effectively doubles the fiber capacity on existing fiber cables.

Key Features

- Auto-recovery
- Link Loss Return and Link Loss Carry Forward
- Full duplex flow control
- Auto-negotiation and MDI-II/MDI-X switches on copper port
- Store-and-forward switching to improve overall network performance by buffering packets to prevent forwarding corrupted packets
- High-performance switching engine that performs forwarding and filtering at full wire speed (148,800 packets per second)
- 1,024 MAC addresses
- VLAN tagging support
- 128K bytes of buffer memory
- Convenient LED indicators located on the top for high visibility
- Integral cable management and protection
- Wall mountable
- Multiple connectivity options, including BWDM
- Stylish, contemporary design in a durable plastic case

Installation Guide

Follow the simple steps outlined in this section to install and start using the Metrobility 10/100Mbps Delta Class AutoTwister.

Unpack the AutoTwister and Accessories

Check that the following parts are included in your box:

- 10/100Mbps Delta Class AutoTwister
- Power supply
- Power supply cord (North American shipments only)
- Four (4) rubber feet

Your order has been provided with the safest possible packaging, but shipping damage occasionally does occur. Inspect your order carefully. If you discover any shipping damage, notify your carrier and follow instructions for damage and claims. Save the original shipping carton if return or storage of the unit is necessary.

Attach the Rubber Feet

The AutoTwister is shipped with four rubber feet located on the black adhesive strip. To install the rubber feet, first turn the AutoTwister upside-down. Peel the feet from the adhesive strip, then attach one foot to each circular indentation on the unit. This provides an air gap which helps to cool the unit, and also adds stability for desktop operation.

If you are stacking the AutoTwister on top of another unit, the rubber feet must be attached to the bottom of the AutoTwister.

Choose an Appropriate Location

The AutoTwister is intended for use in either an office or a residential environment. The unit must be located within six (6) feet of the AC power source being used and placed as far away as possible from electrical noise generating equipment such as copiers, electrostatic printers, and other motorized equipment. If exposed twisted-pair wiring is used nearby, the wiring should be routed as far away as possible from power cords and data cables to minimize interference.

The unit may be oriented in any manner which allows you to make the physical connection to the power supply and leaves a minimum of six (6) inches of space for proper ventilation.

Wall Mounting

The AutoTwister requires no additional hardware for wall mounting. After selecting an appropriate place for installation, simply align the 1/4" keyhole opening on the bottom of the unit to a screw (6-32 maximum head size) or wall anchor. Once you have it positioned properly, make sure the device is attached securely.

Set the Switches

MDI-II/MDI-X Switch

To eliminate the need for crossover cables, the AutoTwister includes an MDI-II/MDI-X switch on the copper port. This push-button switch is located in the center of the front panel and enables either a straight-through or crossover configuration.

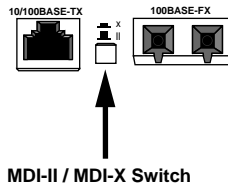

When setting the switch, note the position of the following symbols:

- The parallel symbol (II) indicates a straight-through or parallel connection. Switch is out. (*default*)
- The cross symbol (X) indicates a crossover connection. Switch is in.

Use the tables below as a guide.

A device that is wired straight through needs one crossover connection:

If the cable is	the MDI-II to MDI-X Switch Setting should be
straight through	X
crossover	II

A device that is wired crossover needs a parallel connection:

If the cable is	the MDI-II to MDI-X Switch Setting should be
straight through	II
crossover	X

DIP Switches

The AutoTwister provides a set of six DIP switches located on the back panel. These switches allow you to select from several modes of operation. The default settings are shown below.

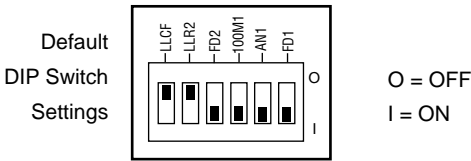

Link Loss Carry Forward Switch (LLCF)

The AutoTwister incorporates Link Loss Carry Forward (LLCF) functionality as an aid in troubleshooting remote connections. When LLCF is enabled, the loss of inbound link pulses on a port stops the transmission of outbound link pulses on the *opposite* port. For example, if LLCF is enabled, the loss of incoming link pulses at *Port 1* will stop the transmission of link pulses out of *Port 2*. Conversely, if *Port 2* stops receiving link pulses, *Port 1* will not transmit link pulses.

Link Loss Carry Forward is enabled on both ports when switch LLCF is ON. The unit is shipped with LLCF disabled. Refer to [Link Loss Carry Forward](#) in the User Guide section of this manual for further details.

Link Loss Return Switch (LLR2)

In addition to LLCF, the AutoTwister supports Link Loss Return functionality to help with troubleshooting remote connections.

Unlike LLCF, which applies to both ports on the AutoTwister, LLR only affects the fiber optic port. When LLR is enabled, the loss of the inbound link pulses on the port stops the transmission of outbound link pulses on the *same* port. For example, if LLR is enabled on port 2 and its receiver (RX) stops detecting link pulses, then port 2's transmitter (TX) will stop sending link pulses. LLR is not applicable to the copper port.

Link Loss Return is enabled on Port 2 when switch LLR2 is ON. The unit is shipped with LLR disabled. Refer to [Link Loss Return](#) in the User Guide section of this manual for more information.

Duplex Switch (FD1, FD2)*

Switch FD1 determines the duplex mode for the copper port when auto-negotiation is disabled. When auto-negotiation is enabled, the FD1 switch setting is ignored. Switch FD2 determines the duplex mode on the

*Changes to switches FD1 and FD2 only come into effect after the power-cycle initialization.

fiber optic port. A port operates at full duplex when its FD switch is ON. It operates at half duplex when its FD switch is OFF. The default is full duplex enabled.

Speed Switch (100M1)*

Switch 100M1 controls the speed setting for the copper port. If auto-negotiation is disabled, the port speed will be the same as this switch setting, where ON is 100Mbps and OFF is 10Mbps. The default speed setting is 100Mbps. When auto-negotiation is enabled, the 100M1 switch setting is ignored.

Auto-Negotiation Switch (AN1)*

Switch AN1 controls the use of auto-negotiation on the copper port. To enable auto-negotiation, set the switch ON. To disable the function, set the switch OFF. By default, auto-negotiation is enabled.

When the copper port has auto-negotiation enabled, it advertises 100Mbps full duplex capabilities. When auto-negotiation is disabled, the port's duplex is set by the FD1 switch, and its speed is set by the 100M1 switch.

DIP Switch Configuration Table

Use the following table to help you set the DIP switches to obtain specific modes of operation. The configuration column lists the speed and duplex options for the copper port (Port 1) on the left and the fiber port (Port 2) on the right. "Auto" indicates that auto-negotiation is enabled.

Configuration (Port 1 - Port 2)	Port 1 (Copper)			Port 2 (Fiber)
	FD1	AN1	100M1	FD2
Auto - 100Mbps Full Duplex	NA	ON	NA	ON
Auto - 100Mbps Half Duplex	NA	ON	NA	OFF
10Mbps Half Duplex - 100Mbps Half Duplex	OFF	OFF	OFF	OFF
10Mbps Half Duplex - 100Mbps Full Duplex	OFF	OFF	OFF	ON
10Mbps Full Duplex - 100Mbps Half Duplex	ON	OFF	OFF	OFF
10Mbps Full Duplex - 100Mbps Full Duplex	ON	OFF	OFF	ON
100Mbps Half Duplex - 100Mbps Half Duplex	OFF	OFF	ON	OFF
100Mbps Half Duplex - 100Mbps Full Duplex	OFF	OFF	ON	ON
100Mbps Full Duplex - 100Mbps Half Duplex	ON	OFF	ON	OFF
100Mbps Full Duplex - 100Mbps Full Duplex	ON	OFF	ON	ON

*Changes to switches 100M1 and AN1 only come into effect after the power-cycle initialization.

Connect to the Network

The Metrobility 10/100Mbps Delta Class AutoTwister offers the ease of plug-and-play installation. The overhang extension provides built-in protection for the two cable connectors.

When making network connections with the AutoTwister, grasp the end of the cable with your index finger on the top of the connector and your thumb on the bottom, as shown in the illustration below. For easier installation, insert the copper cable to the AutoTwister before connecting the fiber.

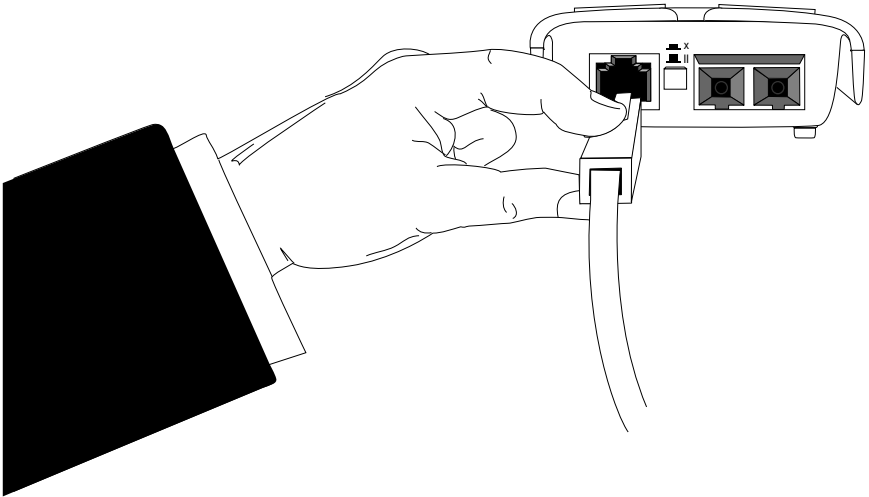

Twisted-Pair Connection

Each AutoTwister provides one shielded RJ-45 connector that supports a maximum segment length of up to 100 meters. Use Category 3, 4 or 5 cables for 10Mbps segments; use only Category 5 or 5E cables for 100Mbps segments.

NOTE: Be sure to properly set the MDI-II/MDI-X switch located between the two port connectors. Refer back to [Set the Switches: MDI-II/MDI-X Switch](#) if necessary.

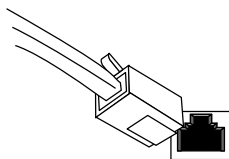

RJ-45

BWDM Connection

The bidirectional wavelength division multiplexed (BWDM) port provides one singlemode SC connector that supports a maximum segment length of 20km. BWDM line cards must always be used in complementary pairs. That is, a -1X model must be connected to a -1Y. The -1X cards are designed to transmit data at a wavelength of 1550nm and receive at 1310nm. Correspondingly, the -1Y cards transmit data at 1310nm and receive at 1550nm.

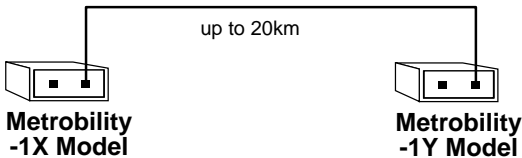

Fiber Optic Connections

- The M643-13, -15, -1G, and -1K provide one set of FX multimode SC / ST / VF-45 / LC connectors, respectively, and support a maximum segment length of up to 2km for remote links.
- The M643-14 and -1M provide one set of FX singlemode SC/LC connectors, respectively, and support a segment length of up to 20km for remote links.
- The M643-17 provides one set of FX singlemode SC connectors and supports a maximum segment length of up to 40km for remote links.
- The M643-1J provides one set of FX singlemode SC connectors and supports a maximum segment length of up to 100km for remote links.

Once power is applied to the unit, correct connectivity can be verified via the link (LK) LEDs if a device is connected to the remote end of the cable.

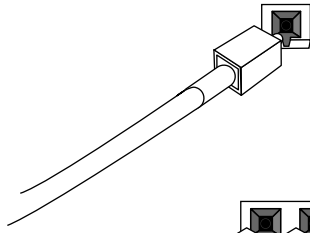

BWDM

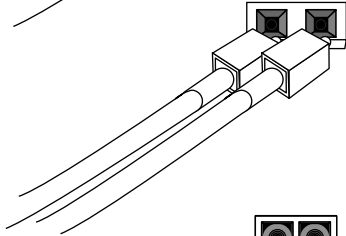

SC

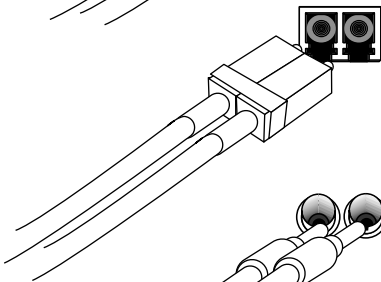

LC

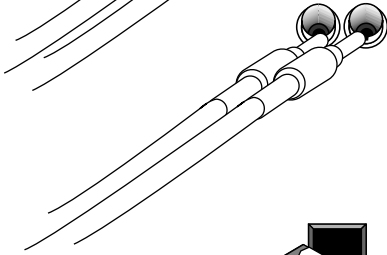

ST

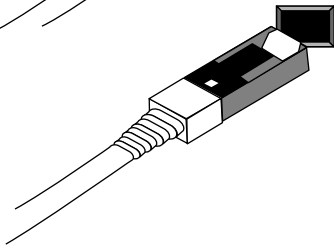

VF-45

Apply Power

Power is applied to the AutoTwister through the desktop power supply. To apply power, do the following:

1. Connect the power cord (not included with international shipments) to the power supply.
2. Connect the power supply to the AutoTwister's DC input power jack located on the back of the unit.
3. The AutoTwister is designed with built-in cable management and protection. Turn the unit upside-down and route the DC power cord into one of the two grooves located on each side of the unit. See diagram.
4. Plug the power cord into an AC wall outlet. Upon receiving power, the power (PWR) LED turns green and the AutoTwister automatically goes into operation providing the appropriate signal translation between connected network segments.
5. Verify valid connections via the link (LK) LEDs, which should be lit.

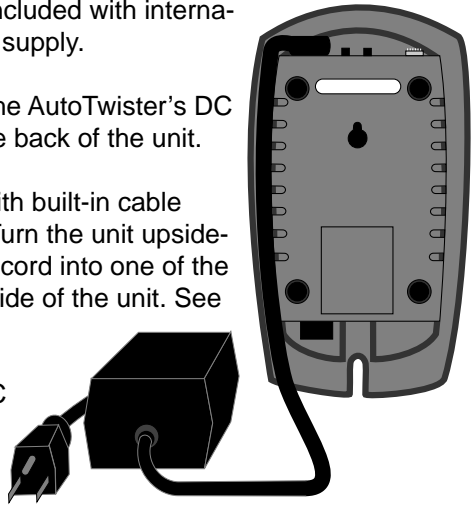

While one end of the AC power cord can be fitted with a plug standard for the country of operation, the end that connects to the AutoTwister's power supply must have a female plug that fits the following type of AC receptacle.

- AC 115V (North America): Use a UL-listed and CSA-certified cord set consisting of a minimum No. 18 AWG, type SVT or SJT three-conductor cord (15 ft maximum length) and a parallel blade grounding type attachment plug rated 15A, 125V.
- AC 230V (USA): Use a UL-listed cord set consisting of a minimum No. 18 AWG, type SVT three-conductor cord (15 ft maximum length) and a Tandem blade grounding type attachment plug rated 15A, 250V.
- 240V (outside USA): Use a cord set consisting of a minimum No. 18 AWG cord and grounding type attachment plug rated 15A, 250V. The cord set should have the appropriate safety approvals for the country in which the AutoTwister is being installed and be marked HAR.

User's Guide

This section contains information regarding the operating features of the Metrobility 10/100Mbps Delta Class AutoTwister.

LED Indicators

The Metrobility 10/100Mbps Delta Class AutoTwister provides several LEDs for the visible verification of unit status and proper functionality. The LEDs can assist in troubleshooting and with overall network diagnosis and management.

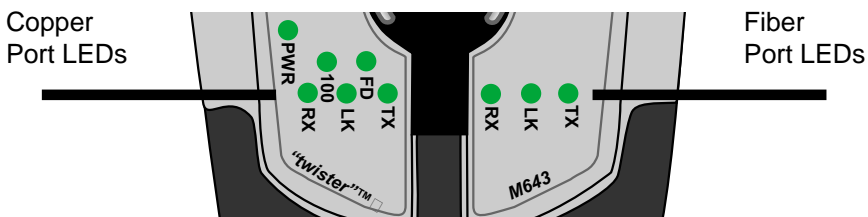

LED Label	LED Name	Color (Status)	Function
PWR	power	green (steady)	The unit is ON.
Copper Port LEDs			
100	speed	green (steady)	The speed setting of the port is 100Mbps when lit. It is 10Mbps when not lit.
FD	duplex	green (steady)	The port is in full-duplex mode when lit. It is in half-duplex mode when not lit.
RX	receive	green (blinking)	The port is receiving data.
LK	link	green (steady)	Verifies that the port has a valid link.
TX	transmit	green (blinking)	The port is sending data.
Fiber Port LEDs			
RX	receive	green (blinking)	The port is receiving data, or the port is attempting auto-recovery.
LK	link	green (steady)	Verifies that the port has a valid link.
TX	transmit	green (blinking)	The port is sending data, or the port is attempting auto-recovery.

Factory Settings

This section describes the preset features on the 10/100Mbps Delta Class AutoTwister. These settings cannot be changed.

Full-Duplex Flow Control

The AutoTwister supports flow control on each port in full duplex only. Full-duplex flow control is provided to avoid dropping packets during network congestion. If there is no buffer space available for incoming packets, the AutoTwister will issue a PAUSE frame. Full-duplex flow control is only applicable to ports operating in full duplex with auto-negotiation enabled. Additionally, during auto-negotiation, the port's link partner must advertise that it supports PAUSE frames.

For ports operating at half duplex, the AutoTwister does not support any type of flow control. If there are not enough buffers available, incoming packets will be dropped.

Auto-Recovery

The AutoTwister includes an auto-recovery circuit that allows you to transparently connect a pair of AutoTwisters between two network devices. This enables you to design a redundant path between 10Mbps and 100Mbps devices, allowing both end devices to detect link loss if any part of the connection fails.

To activate auto-recovery, all of the following conditions must be met:

- Auto-negotiation is disabled.
- LLR is enabled.
- LLCF is enabled.

When auto-recovery is enabled, the AutoTwister attempts to establish the fiber link between two back-to-back units. When LLR is enabled on two adjoining AutoTwisters, it creates a deadlock situation with each fiber port waiting for the other to transmit first. Auto-recovery breaks the deadlock by periodically sending out pulses from the fiber port allowing the AutoTwister to reestablish its fiber link.

Link Loss Return (LLR)

The fiber optic ports of the Metrobility AutoTwister have been designed with LLR* functionality for troubleshooting a remote connection.

When LLR is enabled, the fiber port's transmitter shuts down when its receiver fails to detect a valid receive link. LLR is normally enabled on one end of the link and is typically enabled on either the unmanaged or remote device. Setting LLR on both ends of the link necessitates auto-recovery. See [Auto-Recovery](#) on page 17.

The diagram below shows a typical network configuration with good link status using AutoTwisters for remote connectivity.

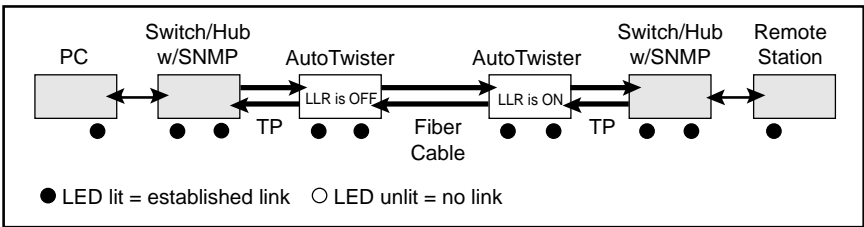

If one of the optical conductors is bad (as shown in the diagram box below), the AutoTwister with LLR enabled will return a no-link condition to its link partner. This aids the network administrator in determining the source of the loss.

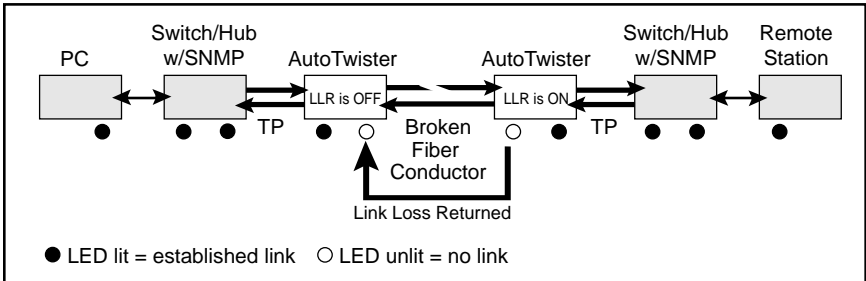

*Units are shipped with the LLR function disabled (OFF).

Link Loss Carry Forward (LLCF)

The AutoTwister incorporates LLCF* for troubleshooting remote connections. When LLCF is enabled, the ports do not transmit a link signal until they receive a link signal from the opposite port.

The diagram below shows a typical network configuration with good link status using Metrobility AutoTwisters for remote connectivity. Note that LLCF is enabled as indicated in the diagram below.

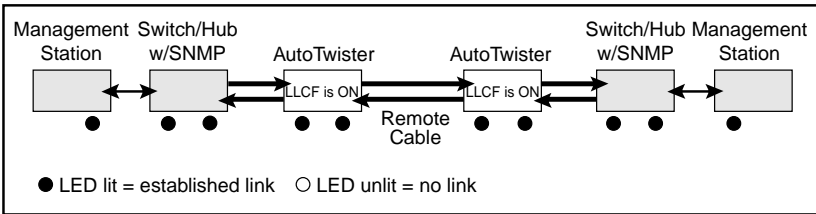

If a connection breaks, the AutoTwisters carry that link loss forward to the switch/hubs which generate a trap to the management stations. A network administrator can then determine the source of the problem.

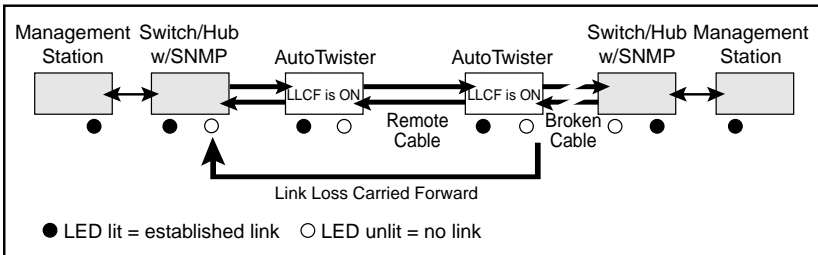
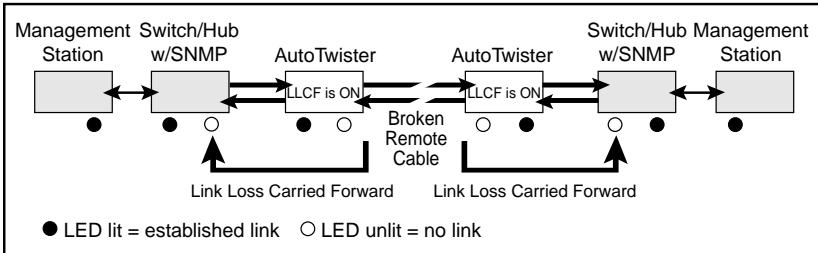

* Units are shipped with LLCF disabled (OFF).

Auto-Recovery

A typical application of the 10/100 AutoTwister is to use it in pairs to extend a network's reach between two distant devices.

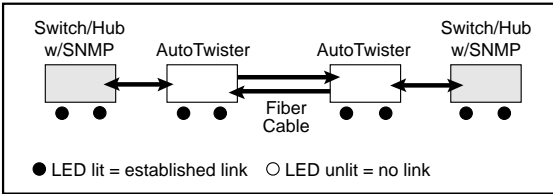

In this back-to-back setup, it may be desirable to see the entire link down if any of the connecting segments fails. This means that both copper ports must relay a no link condition to the switch/hub when any of the cables is broken.

For proper operation in this configuration, auto-recovery must be enabled. In the standalone AutoTwister, auto-recovery is enabled only when all of the following switches are set as indicated:

AN1 = disabled (OFF) LLR2 = enabled (ON) LLCF = enabled (ON)

Because LLR is enabled on both units, auto-recovery is required to prevent the two fiber ports from ending up in a deadlock situation, with each waiting for the other to transmit first. Auto-recovery allows the deadlock to be broken by periodically sending out pulses from the fiber port forcing the AutoTwister to establish its fiber link if the line is intact.

The diagrams below show how the two switch/hubs are alerted to a broken fiber cable. Notice that both LLR and LLCF must be enabled under these conditions.

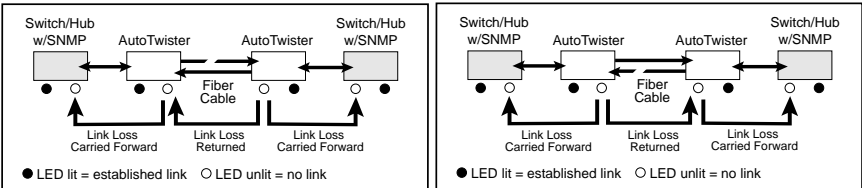

Auto-Recovery Application Example

A set of four AutoTwisters can be used to provide the redundancy necessary to ensure that data from a 100Mbps device reaches its destination in a 10Mbps device, as illustrated in the diagram below. In this example, the main link, which includes AutoTwisters A1 and A2, must be seen as a single connection. If any of the cables in the main link fails, both switch/hubs must be notified of the failure so they can activate the backup link, which includes AutoTwisters B1 and B2.

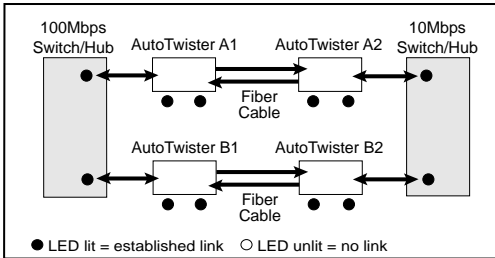

Since the entire main link must appear down if any of its connecting segments fails, the copper ports of AutoTwisters A1 and A2 must be able to indicate a no-link condition to their corresponding switch/hubs. To do this,

auto-recovery must be enabled on the two AutoTwisters.

To enable auto-recovery on the AutoTwisters, make sure that on each unit, AN1 is disabled, LLR2 is enabled, and LLCF is enabled.

The diagram below illustrates how the two switch/hubs are alerted to a broken fiber cable in the main link, thus activating the backup link with AutoTwisters B1 and B2.

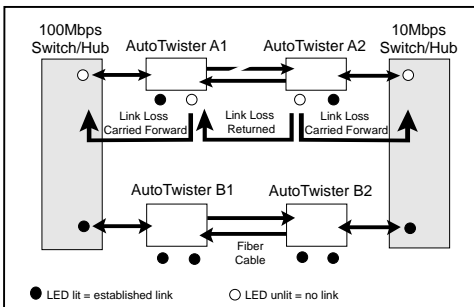

Sequence of events:

- AutoTwister A1 stops transmitting data to AutoTwister A2.
- AutoTwister A2 senses the loss of link and stops transmitting link pulses to AutoTwister A1 and the 10Mbps switch/hub.
- AutoTwister A1 receives the no link condition and stops transmitting link pulses to the 100Mbps switch.
- The 100Mbps and 10Mbps switch/hubs detect that the main link is down and switch traffic to the backup link.
- Traffic resumes via the backup path with AutoTwisters B1 and B2.
- Because auto-recovery is enabled, AutoTwisters A1 and A2 try to reestablish the fiber link by periodically sending out pulses from their fiber ports.

Topology Solution

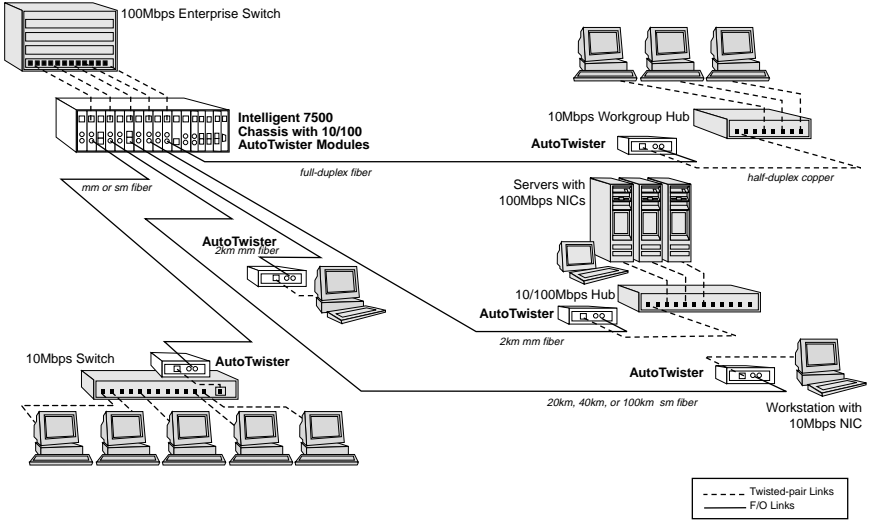

Technical Specifications

Network Connections

Twisted-Pair Interface

Connector _____ Shielded RJ-45, 8-pin jack
Impedance _____ 100 Ohms nominal
Signal Level Output (peak differential) _____ .95 to 1.05V (100Mbps)
_____ 2.2 to 2.8V (10Mbps)
Signal Level Input _____ 200mV minimum (100Mbps)
_____ 585mV minimum (10Mbps)
Supported Link Length _____ 100m
Cable Type _____ (10Mbps segments) Category 3, 4 or 5 UTP/STP
_____ (100Mbps segments) Category 5 or 5E UTP/STP

Multimode Fiber Optic Interface

(M643-13, M643-15, M643-1G, M643-1K)

Connector _____ SC, ST, VF-45, LC
Wavelength _____ 1310nm
RX Input Sensitivity _____ -31 dBm maximum
Output Power _____ -23.5 dBm to -14 dBm (50/125 μ m)
_____ -20 dBm to -14 dBm (62.5/125 μ m)
Supported Link Length _____ up to 2km full duplex
Cable Type _____ 50/125, 62.5/125 μ m F/O

Singlemode Fiber Optic Interface

(M643-14, M643-1M)

Connector _____ SC, LC
Wavelength _____ 1310nm
RX Input Sensitivity _____ -31 dBm maximum
Output Power _____ -15 dBm to -8 dBm (9/125 μ m)
Supported Link Length _____ up to 20km full duplex
Cable Type _____ 9/125 μ m F/O

Singlemode Fiber Optic Interface — long haul distance support

(M643-17)

Connector _____ SC
Wavelength _____ 1310nm
RX Input Sensitivity _____ -31 dBm maximum
Output Power _____ -5 dBm to 0 dBm (9/125 μ m)
Supported Link Length _____ up to 40km full duplex
Cable Type _____ 9/125 μ m F/O

Singlemode Fiber Optic Interface — extended long haul distance support

(M643-1J)

Connector _____ SC
Wavelength _____ 1550nm
RX Input Sensitivity _____ -37 dBm minimum
Output Power _____ -3 dBm to 0 dBm (9/125 μ m)
Supported Link Length _____ up to 100km full duplex
Cable Type _____ 9/125 μ m F/O

Singlemode BWDM Fiber Optic Interface

(M643-1X, M643-1Y)

Connector _____ SC
Supported Link Length _____ up to 20km full duplex
Cable Type _____ 9/125 μ m F/O
RX Input Sensitivity _____ -32 dBm minimum
Output Power _____ -15 dBm to -8 dBm (9/125 μ m)

(M643-1X)

TX Wavelength _____ 1550nm

RX Wavelength _____ 1310nm

(M643-1Y)

TX Wavelength _____ 1310nm

RX Wavelength _____ 1550nm

Data Rate

Data Rate _____ 100Mbps half duplex; 200Mbps full duplex (Fast Ethernet)
_____ 10Mbps half duplex; 20Mbps full duplex (Ethernet)

Power

Input _____ 90-260V AC 50/60 Hz
Output _____ + 5V @ 1Amp, 5W

Environmental

Operating Temperature _____ 0° to 50° C

Storage Temperature _____ -25° to 70° C

Relative Humidity _____ 5% to 95% non-condensing

Physical Case _____ Impact-resistant plastic construction

Dimensions _____ 7" L x 3.75" W x 1.5" H

_____ 17.8 cm x 9.5 cm x 3.8 cm

Weight (including power supply) _____ 1.2 lbs, 0.55 kg

Product Safety, EMC, and Compliance Statements

This equipment complies with the following requirements:

- UL
- CSA
- FCC Part 15, Class A
- EN55024: 1998 (immunity)
- IEC 825-1 Classification
- CE
- EN60950 (safety)
- EN55022 Class A (emissions)
- Class 1 Laser Product
- DOC Class A (emissions)

This product shall be handled, stored and disposed of in accordance with all governing and applicable safety and environmental regulatory agency requirements.

The following *FCC* and *Industry Canada* compliance information is applicable to North American customers only.

USA FCC Radio Frequency Interference Statement

This equipment has been tested and found to comply with the limits for a Class A digital device, pursuant to Part 15 of the FCC Rules. These limits are designed to provide reasonable protection against harmful interference when the equipment is operated in a commercial environment. This equipment generates, uses and can radiate radio frequency energy, and if not installed and used in accordance with the instruction manual, may cause harmful interference to radio communications. Operation of this equipment in a residential area is likely to cause harmful interference in which case the user will be required to correct the interference at his own expense.

Caution: *Changes or modifications to this equipment not expressly approved by the party responsible for compliance could void the user's authority to operate the equipment.*

Canadian Radio Frequency Interference Statement

This Class A digital apparatus meets all requirements of the Canadian Interference-Causing Equipment Regulations.

Cet appareil numérique de la classe A respecte toutes les exigences du Règlement sur le matériel brouilleur du Canada.

Warranty and Servicing

Three-Year Warranty for the Metrobility 10/100Mbps AutoTwister

Metrobility Optical Systems, Inc. warrants that every Metrobility 10/100Mbps Delta Class AutoTwister will be free from defects in material and workmanship for a period of THREE YEARS. This warranty covers the original user only and is not transferable. Should the unit fail at any time during this warranty period, Metrobility will, at its sole discretion, replace, repair, or refund the purchase price of the product. This warranty is limited to defects in workmanship and materials and does not cover damage from accident, acts of God, neglect, contamination, misuse or abnormal conditions of operation or handling, including overvoltage failures caused by use outside of the product's specified rating, or normal wear and tear of mechanical components.

To establish original ownership and provide date of purchase, complete and return the registration card or register the product online at www.metrobility.com. If product was not purchased directly from Metrobility, please provide source, invoice number and date of purchase.

To return a defective product for warranty coverage, contact Metrobility Customer Service for a return materials authorization (RMA) number. Send the defective product postage and insurance prepaid to the address provided to you by the Metrobility Technical Support Representative. Failure to properly protect the product during shipping may void this warranty. The Metrobility RMA number must be clearly on the outside of the carton to ensure its acceptance.

Metrobility will pay return transportation for product repaired or replaced in-warranty. Before making any repair not covered by the warranty, Metrobility will estimate cost and obtain authorization, then invoice for repair and return transportation. Metrobility reserves the right to charge for all testing and shipping costs incurred, if test results determine that the unit is without defect.

This warranty constitutes the buyer's sole remedy. No other warranties, such as fitness for a particular purpose, are expressed or implied. Under no circumstances will Metrobility be liable for any damages incurred by the use of this product including, but not limited to, lost profits, lost savings, and incidental or consequential damages arising from the use of, or inability to use, this product. Authorized resellers are not authorized to extend any other warranty on Metrobility's behalf.

Product Manuals

The most recent version of this manual is available online at
<http://www.metrobility.com/support/manuals.htm>

To obtain additional copies of this manual, contact your reseller, or call
1.877.526.2278 or 1.603.880.1833

Product Registration

To register your product, go to
<http://www.metrobility.com/support/registration.cfm>

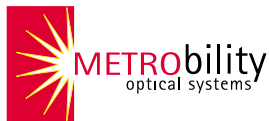

25 Manchester Street, Merrimack, NH 03054 USA
tel: 1.603.880.1833 • fax: 1.603.594.2887
www.metrobility.com

5660-000045 B
11/02